

Electrical Characteristics										
Frequency	Hz	50				60				
Voltage (parallel star)	V	380	400	415	440	415	440	460	480	
Rated power class H	kVA	930	930	930	840	1020	1060	1116	1116	
	kW	744	744	744	672	816	848	893	893	
Rated power class F	kVA	850	850	850	770	935	969	1020	1020	
	kW	680	680	680	616,0	748	775	816	816	
Regulation with UVR6		±1% with any power factor and speed variations between -5% +30%								
Insulation class		H								
Execution		Brushless								
Stator winding		12 ends								
Rotor		with damping cage								
Efficiencies class H	4/4	%	95,5	95,4	95,2	95	95,2	95,7	95,9	95,8
(see graph. for details)	3/4	%	95,8	95,7	95,5	95,6	95,4	95,6	96	95,8
	2/4	%	94,5	94,4	94,3	94,1	94,5	94,6	94,8	94,7
	1/4	%	92	92	91,8	91,3	93	93	93	93
Reactances (f. l.cl. F)	Xd	%	414,4	374	347,5	280,0	458,6	422,8	407,2	374
	Xd'	%	18,3	16,54	15,4	12,4	20,3	18,7	18,01	16,54
	Xd''	%	8,7	7,81	7,3	5,8	9,6	8,8	8,5	7,81
	Xq	%	170,6	154	143,1	115,3	188,9	174,1	167,7	154
	Xq'	%	170,6	154	143,1	115,3	188,9	174,1	167,7	154
	Xq''	%	21,5	19,38	18	14,5	23,8	21,9	21,1	19,38
	X ₂	%	15,1	13,6	12,6	10,2	16,7	15,4	14,8	13,6
	X ₀	%	4,1	3,7	3,4	2,8	4,5	4,2	4,03	3,7
Short Circuit Ratio	Kcc		0,28	0,33	0,38	0,48	0,19	0,23	0,28	0,33
Time Constants	Td'	sec.	0,234							
	Td''	sec.	0,0169							
	Tdo'	sec.	8,30							
	Tα	sec.	0,0223							
Short Circuit Current Capacity		%	>300				>350			
Excitation at no load	Amp.		0,5	0,6	0,8	0,9	0,3	0,4	0,5	0,6
Excitation at full load	Amp.		2,5	2,8	3	3,2	2,3	2,4	2,5	2,8
Overload (long-term)	%	1 hour in a 6 hours period 110% rated load								
Overload per 20 sec.	%	300								
Stator Winding Resistance (20°C)	Ω	0,0086								
Rotor Winding Resistance (20°C)	Ω	3,020								
Exciter Resistance (20 °C)	Ω	Rotor : 0,130				Stator : 10,63				
Heat dissipation at f.l.cl.H	W	35058	35874	37513	35368	41143	38102	38170	39142	
Telephone Interference		FHT < 2%				TIF < 40				
Radio interference		EN50081-1, EN50082-1, VDE0875K. For others standards apply to factory								
Waveform Distors.(THD) at f. load	LL/LN %	2 / 2,3								
Waveform Distors.(THD) at no load	LL/LN %	2,7 / 2,9								
Mechanical characteristics										
Protection		IP 23 (other protection on request)								
DE bearing		NU2224								
NDE bearing		6322								
Weight of wound stator assembly	kg	731								
Weight of wound rotor assembly	kg	551								
Weight of complete generator	kg	2090								
Maximun overspeed	rpm	2250								
Unbalanced magnetic pull at f.l.cl.F	kN/mm	5,7								
Cooling air requirement	m ³ /min	90				108				
Inertia Constant (H)	sec.	0,255				0,306				
Noise level at 1m/7m	dB(A)	95 / 84				99 / 89				

All technical data are to be considered as a reference and they can be modified without any notice.

This document is a propriety of Mecc Alte S.p.A.. All rights reserved.

50 Hz

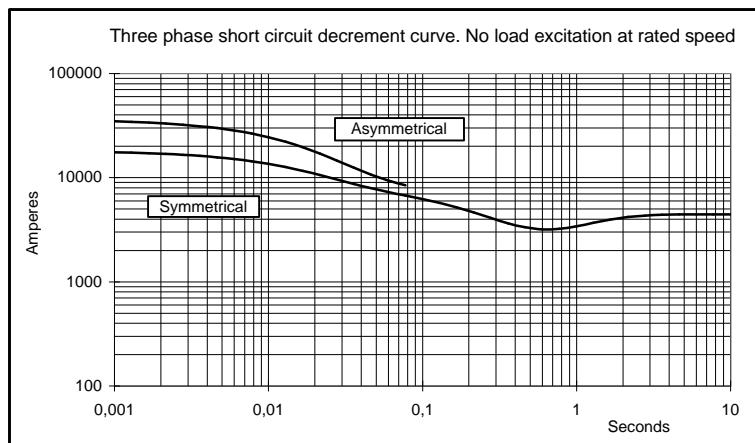
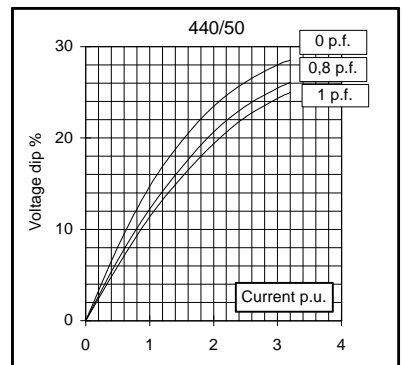
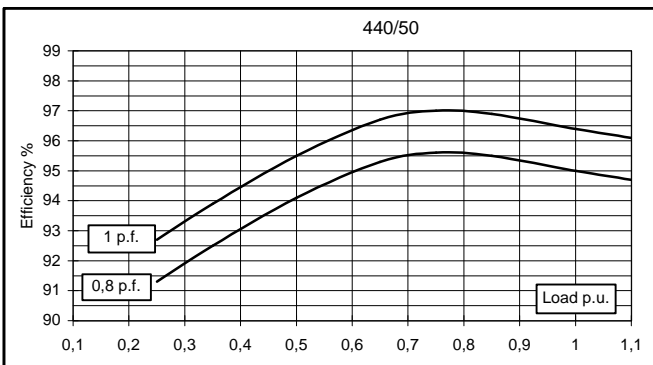
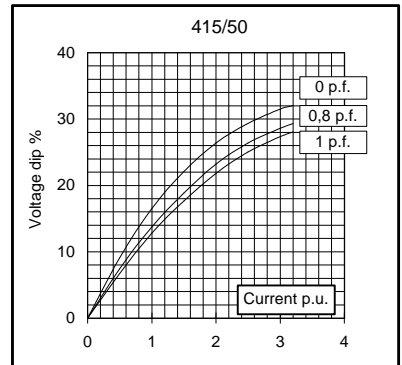
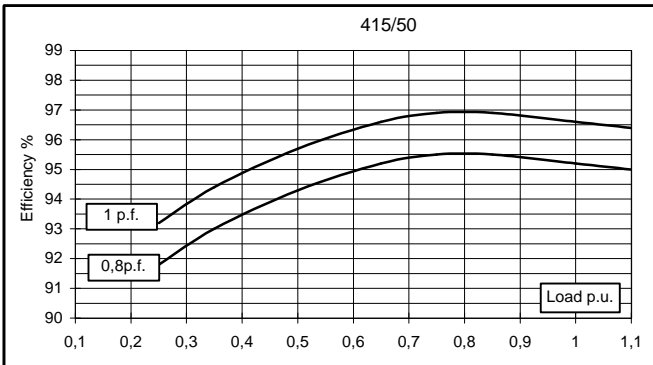
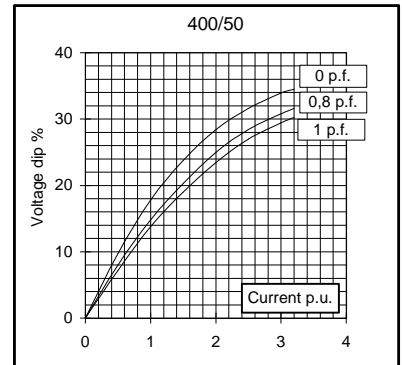
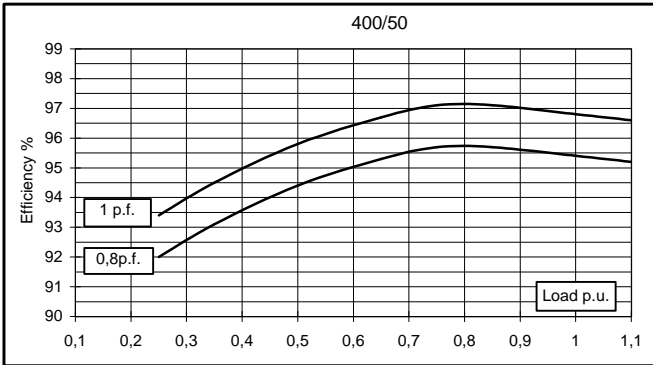
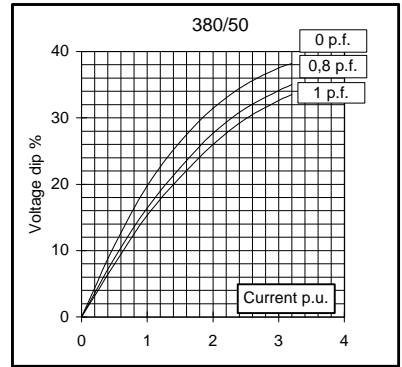
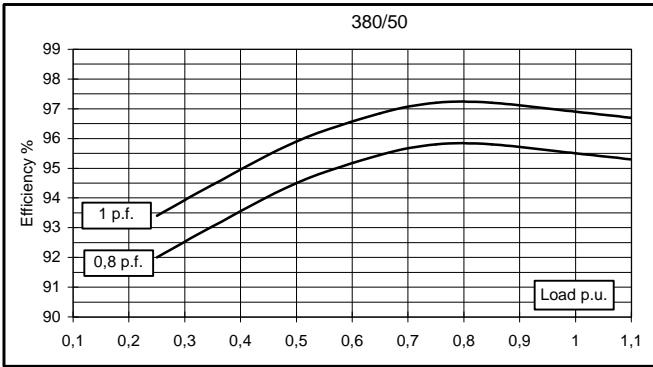

60 Hz

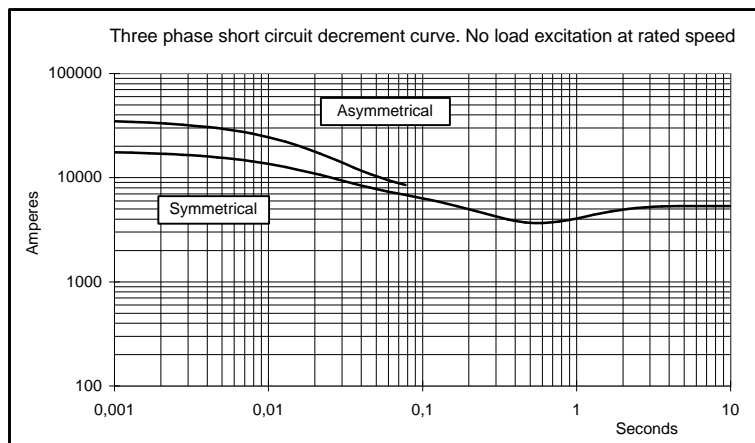
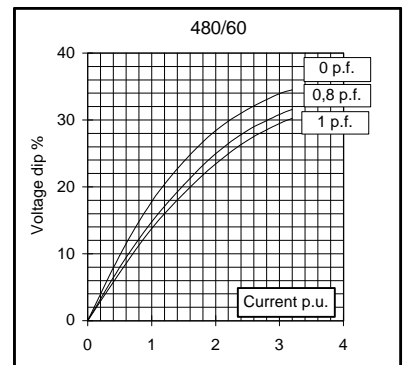
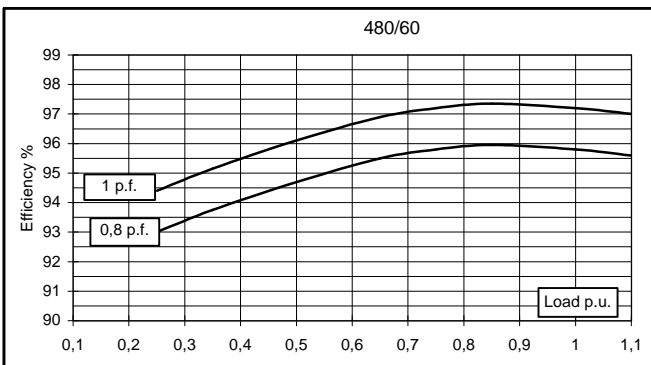
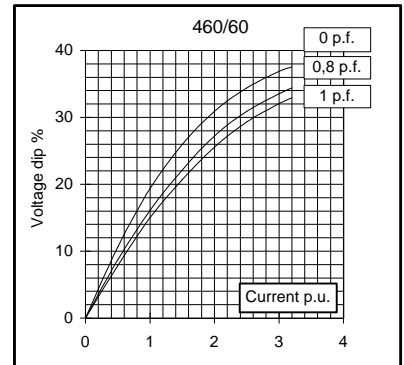
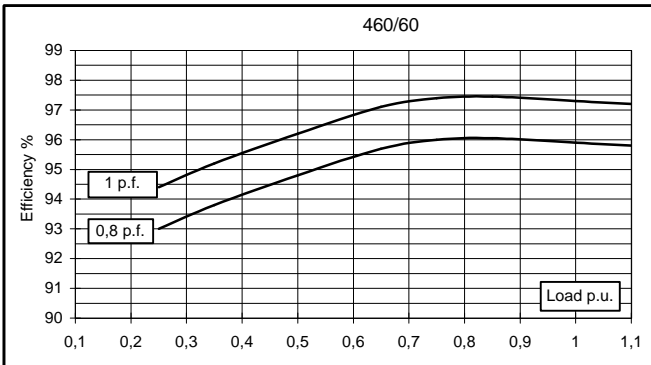
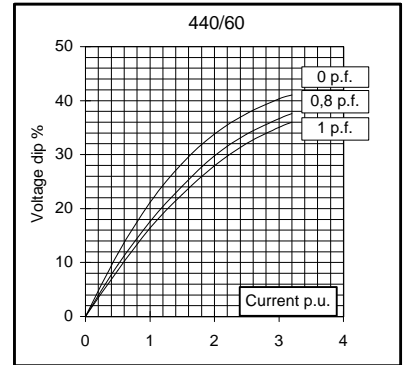
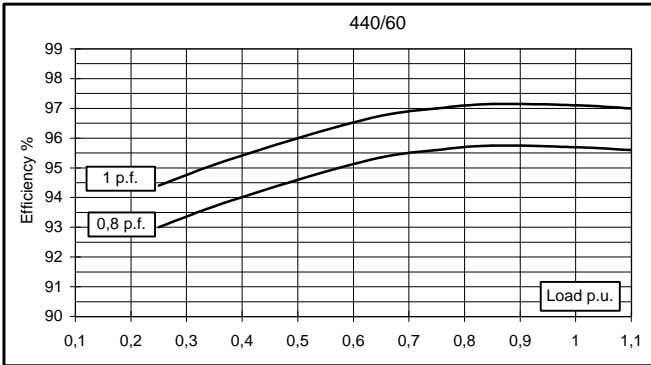
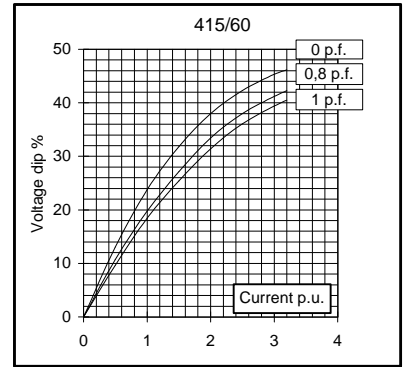
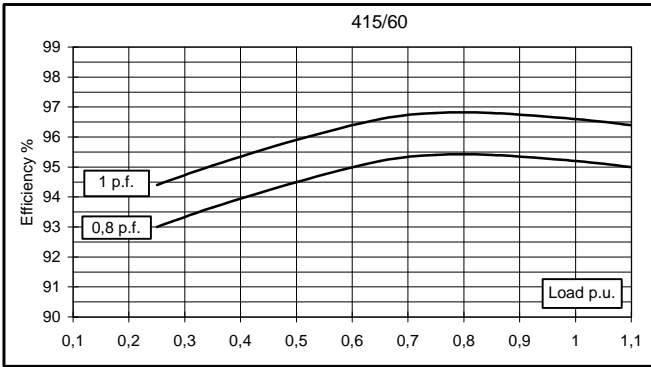

TWO BEARING MOMENTS OF INERTIA

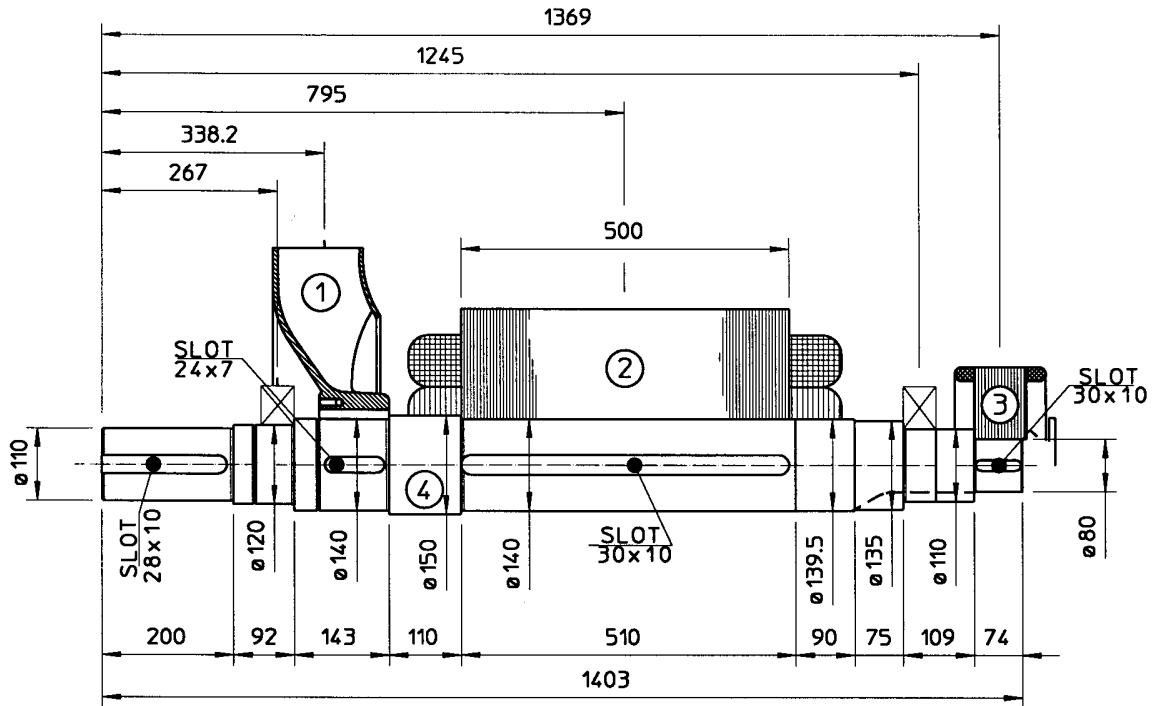

COMPONENT	WEIGHT kg	J kgm ²
1 FAN	27	1.12
2 MAIN ROTOR	551	16.965
3 EX. ROTOR	40	0.629
4 SHAFT	147.1	0.426
TOTAL	765.1	19.14

TWO BEARING DIMENSIONS

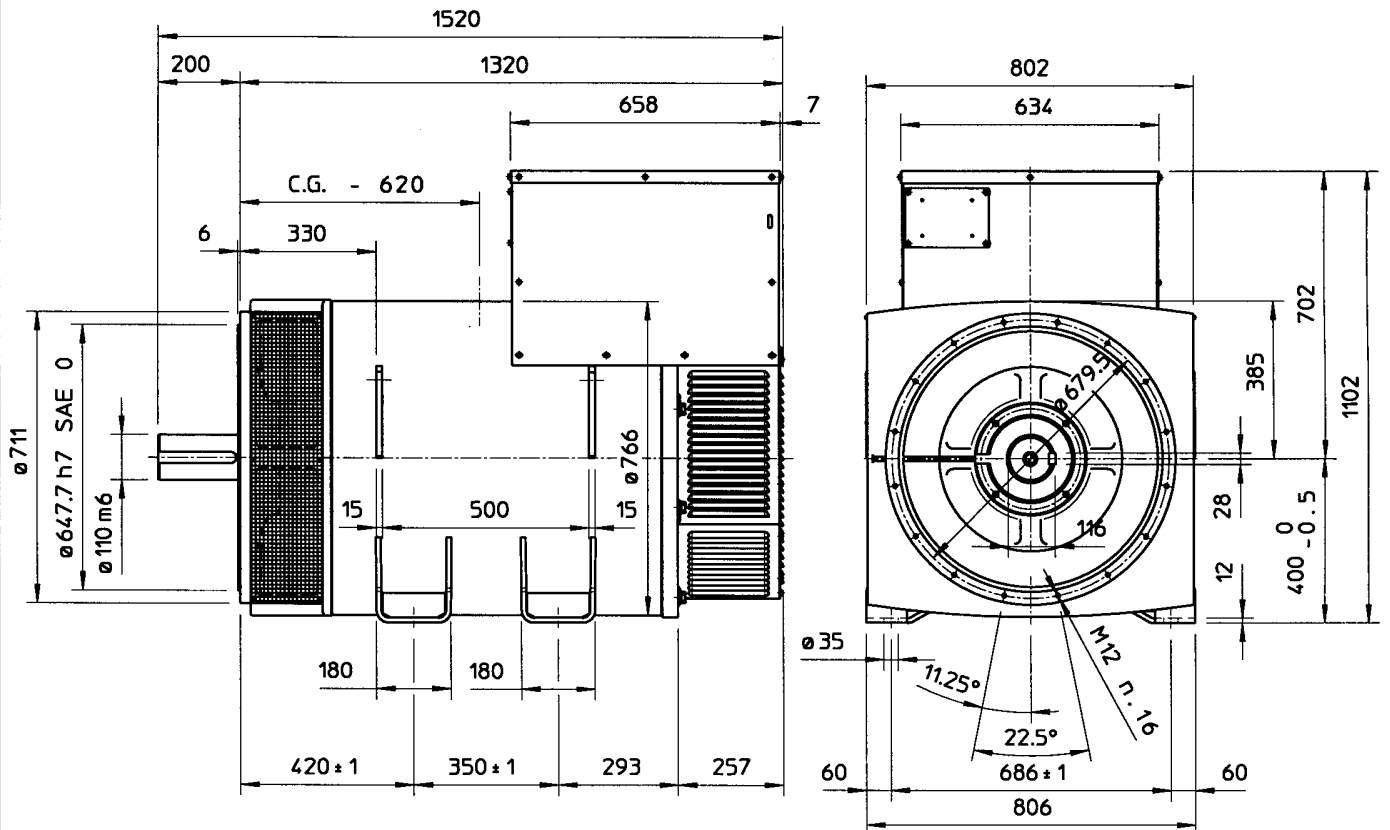

C.G.= GRAVITY CENTER

SINGLE BEARING MOMENTS OF INERTIA

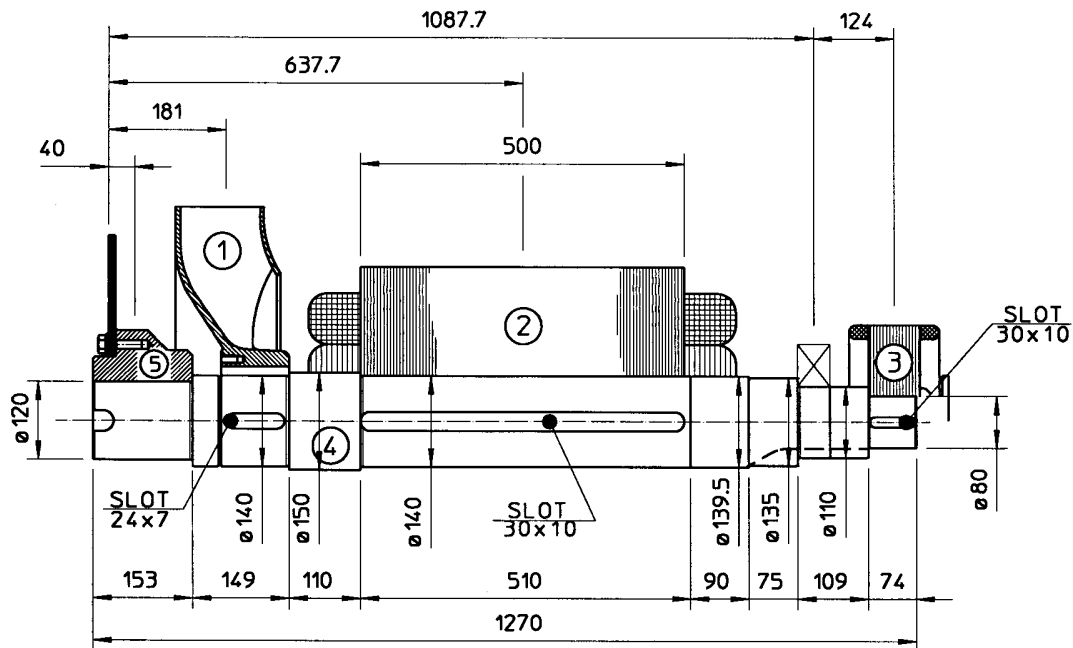

COMPONENT	WEIGHT kg	J kgm ²
1 FAN	27	1.12
2 MAIN ROTOR	551	16.965
3 EX. ROTOR	40	0.629
4 SHAFT	138.6	0.402
TOTAL	756.6	19.116

SAE N.	5 SHAFTS COUPLING FLEX PLATE	WEIGHT kg	J kgm ²
18		69.9	1.065

SINGLE BEARING DIMENSIONS

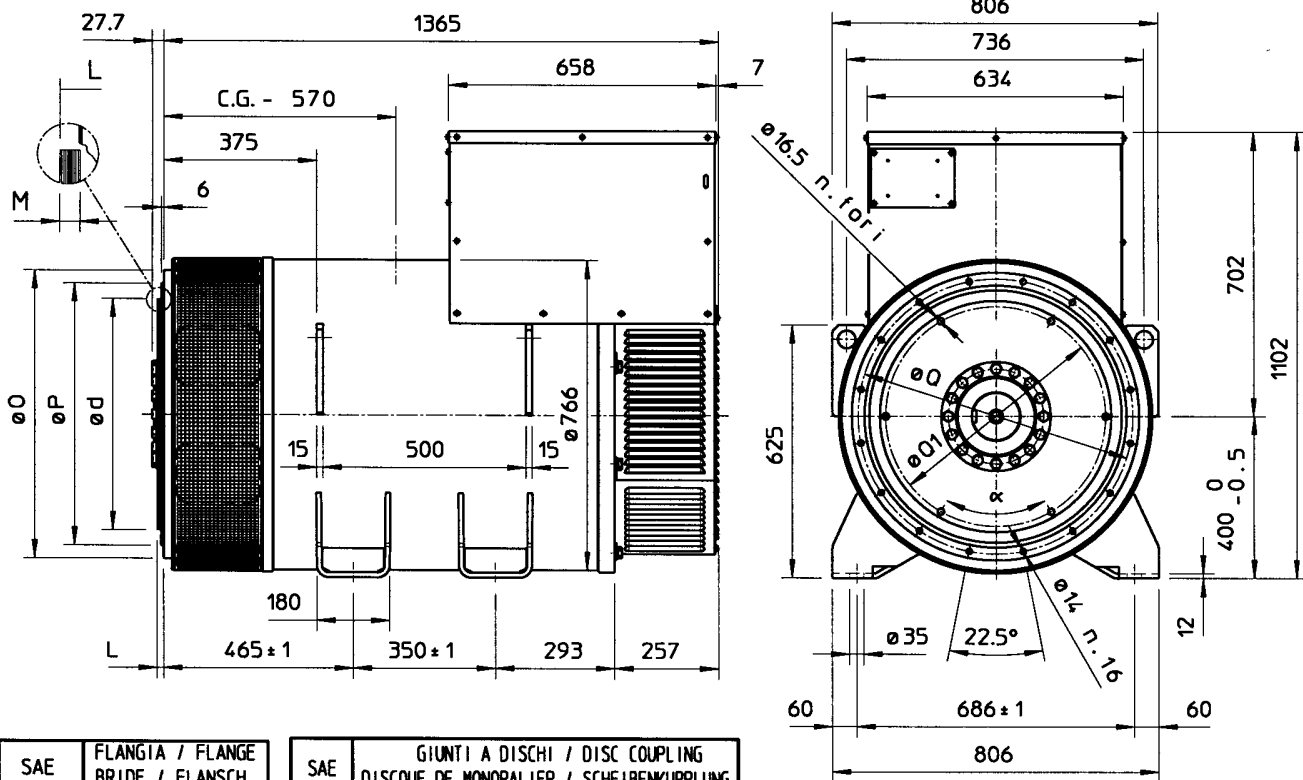

SAE N.	FLANGIA / FLANGE BRIDE / FLANSCH		
	O	P	Q
0	711	647.7	679.5
00	883	787.4	850.9

SAE N.	GIUNTI A DISCHI / DISC COUPLING DISQUE DE MONOPALIER / SCHEIBENKUPPLUNG					
	d	L	M	Q1	N.FORI	α
18	571.5	15.7	10	542.92	6	60°
21	673.1	0	12	641.35	12	30°

C.G. = GRAVITY CENTER